

# Order picking trucks 1.0 ton

## BT optio

*N-series*

TSE100W

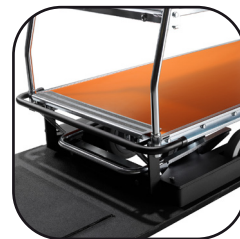

# Order Picking Truck

Specifications					TSE100W - 709	TSE100W - 710	TSE100W - 713
Identification	1.2	Model			TSE100W - 709	TSE100W - 710	TSE100W - 713
	1.3	Drive			Electric	Electric	Electric
	1.4	Operator type			Stand on	Stand on	Stand on
	1.5	Load capacity/rated load	Q	kg	1000	1000	1000
	1.9	Wheelbase	y	mm	1165	1165	1053
Weight	2.1	Service weight including battery		kg	260 <sup>1)</sup>	280 <sup>1)</sup>	300 <sup>1)</sup>
	2.2	Axle load, with load, drive/castor/support arm wheel		kg	156/34/610	168/36/629	180/47/81
	2.3	Axle load, without load, drive/castor/support arm wheel		kg	156/34/70	168/36/89	180/47/81
Wheels	3.1	Drive/castor/fork wheel			Polyurethane/Polyurethane/Elastic		
	3.2	Wheel size, front		mm	Ø 250x80	Ø 250x80	Ø 250x80
	3.3	Wheel size, rear		mm	Ø 200x50	Ø 200x50	Ø 200x50
Dimensions	4.2.1	Overall height	$h_{15}$	mm	1091	1091	1091
	4.8	Stand height	$h_7$	mm	70	70	70
	4.12	Coupling height	$h_{10}$	mm	92	92	83
	4.19	Overall length	$l_1$	mm	1583	1583	1475
	4.21	Overall width	$b_1/ b_2$	mm	747/730	975/945	1327/1292
	4.32	Ground clearance, centre of wheelbase	$m_2$	mm	33	33	33
	4.35	Turning radius	$W_a$	mm	1432	1440	1320
	4.44	Clear width driver compartment entrance	$l_{24}$	mm	426	426	418
Performance data	5.1	Travel speed, with/without load		km/h	9,0/12,0	9,0/12,0	9,0/12,0
	5.7	Gradeability, with/without load		%	10/10	10/10	10/10
	5.9	Acceleration time, with/without load (0-10m)		s	5,7/4,7	5,7/4,7	5,7/4,7
	5.10	Service brake			Electromagnetic		
Electric motor	6.1	Drive motor rating S2 60 min		kW	1,0	1,0	1,0
	6.4	Battery voltage/nominal capacity $K_5$		V/Ah	24/76 - 105	24/76 - 105	24/76 - 105
	6.5	Battery weight		kg	58/75	58/75	58/75
	6.6	Energy consumption according to VDI cycle <sup>2)</sup>		kWh/h	—	—	—
Others	8.1	Type of drive control			Variable AC	Variable AC	Variable AC
	8.4	Sound level at the driver's ear according to EN 12053		dB (A)	<70	<70	<70

1) With 105 Ah battery.

2) Contact your supplier for information.

All data are based on table configuration. Other configurations may give other values.

Truck performance and dimensions are nominal and subject to tolerances.

Toyota Material Handling Manufacturing Sweden AB products and specifications are subject to change without notice.

# Dimensional drawings

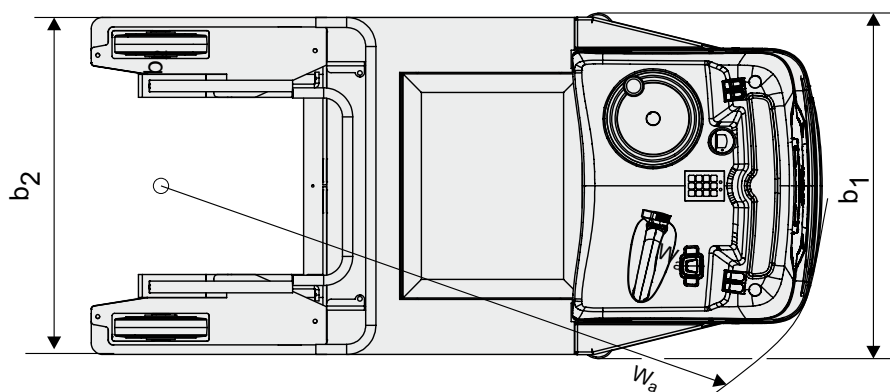
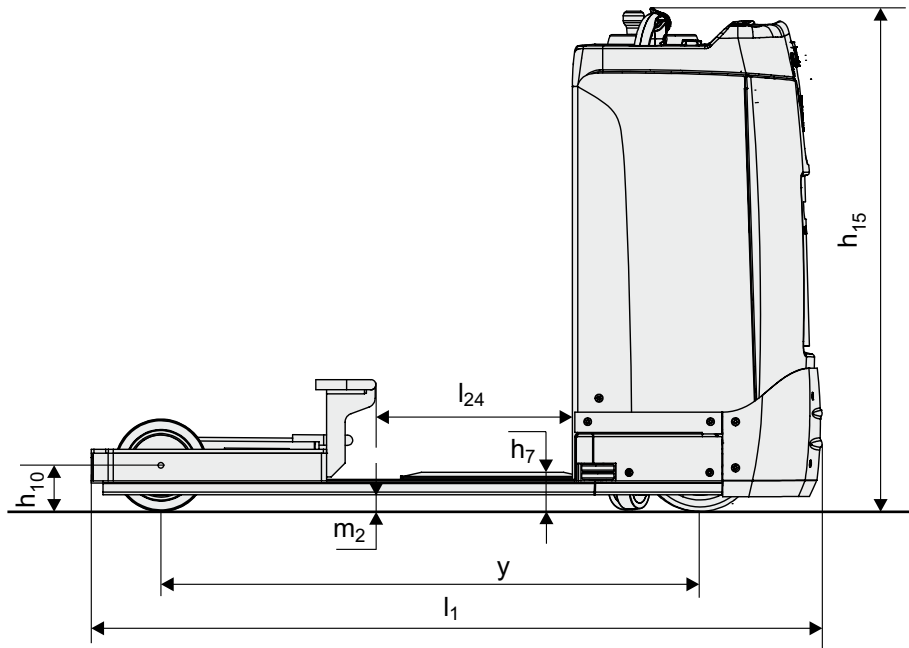

---

## Truck features:

- BT Optio N-series orderpicking trucks offer flexible, efficient and frequent material handling.
- The trucks and carriers are simple to use and ergonomically designed.
- The concept is based on order picking from or to carriers.
- Unique docking system tow tractor - carrier.
- Productivity can be increased up to 50% compared with manual picking.
- Up to 1000 kg towing capacity.
- Low instep. Only 70 mm.
- Low weight.
- Programmable performances. Maximum speed 12 km/h.
- Easy service accessibility.
- External charger and built-in battery cassette for convenient change.



TMHE-Toyota Material Handling Europe — 746803-040, version 4, 2023-08-09

**TOYOTA**

MATERIAL HANDLING