

Pedestrian stacker truck 1.2 - 1.4 ton



BT staxio

W-series

SWE120

SWE140



Pedestrian stacker

Specification for stacker trucks						SWE120	SWE140
Identification	1.1	Manufacturer				Toyota	Toyota
	1.2	Model				SWE120	SWE140
	1.3	Drive				Electric	Electric
	1.4	Operator type				Pedestrian	Pedestrian
	1.5	Load capacity/rated load	Q	kg		1200	1400
	1.6	Load centre	c	mm		600	600
	1.8	Load distance, centre of support arm wheel to face of forks	x	mm		645	645
	1.9	Wheelbase	y	mm		1252	1252
	Weight	2.1	Service weight including battery		kg		907
2.2		Axle load, with load, drive/castor/support arm wheel		kg		400/290/1445	450/245/1640
2.3		Axle load, without load, drive/castor/support arm wheel		kg		400/250/285	450/200/285
Wheels	3.1	Drive/castor/fork wheel				Polyurethane	Polyurethane
	3.2	Wheel size, front		mm		Ø230x70	Ø230x70
	3.3	Wheel size, rear		mm		Ø85x95	Ø85x95
	3.4	Additional wheels (dimensions)		mm		Ø125x50	Ø125x50
	3.5	Wheels, number front/rear (x = driven wheels)				1x+2/2	1x+2/2
	3.6	Track width, front	b ₁₀	mm		550	550
	3.7	Track width, rear	b ₁₁	mm		390	390
Dimensions	4.2	Height, mast lowered	h ₁	mm		2143 *)	2168 *)
	4.3	Free lift	h ₂	mm		76 *)	76 *)
	4.4	Lift	h ₃	mm		3210 *)	3165 *)
		Lift height	h ₂₃	mm		3300 *)	3255 *)
	4.5	Height, mast extended	h ₄	mm		3720 *)	3725 *)
	4.8	Stand height (optional platform)	h ₇	mm		150	150
	4.9	Height of tiller in drive position without platform, min./max.	h ₁₄	mm		865/1235	865/1235
		Height of tiller in drive position with platform, min./max.	h ₁₄	mm		1055/1235	1055/1235
	4.15	Height, fork lowered	h ₁₃	mm		90	90
	4.19	Overall length	l ₁	mm		1906	1906
	4.20	Length to face of forks	l ₂	mm		756	756
	4.21	Overall width	b ₁	mm		770	770 *)
	4.22	Fork dimensions	s/e/l	mm		60/180/1150 *)	70/180/1150 *)
	4.24	Fork-carriage width	b ₃	mm		674	674
	4.25	Width over forks	b ₅	mm		570 *)	570 *)
	4.31	Ground clearance, with load, below mast	m ₁	mm		27	27
4.32	Ground clearance, centre of wheelbase	m ₂	mm		27	27	
4.34.1	Aisle width for pallets 1000x1200 crossways	A _{st}	mm		2300	2300	
4.34.2	Aisle width for pallets 800x1200 lengthways	A _{st}	mm		2287	2287	
4.35	Turning radius	W _a	mm		1403	1403	
Performance data	5.1	Travel speed, with/without load		km/h		6/6	6/6
	5.2	Lift speed, with/without load		m/s		0.12/0.28	0.11/0.28
	5.3	Lowering speed, with/without load		m/s		0.38/0.38	0.37/0.38
	5.8	Max. gradeability, with/without load		%		8/12 ¹⁾	8/12 ¹⁾
	5.10	Service brake				Electromagnetic	Electromagnetic
Electric motor	6.1	Drive motor rating S2 60 min		kW		1.0	1.5
	6.2	Lift motor rating at S3 15%		kW		2.2 ²⁾	2.2 ²⁾
	6.4	Battery voltage/nominal capacity K _s		V/Ah		24/225 *)	24/225 *)
	6.5	Battery weight		kg		192 ¹⁾	192 ¹⁾
	6.6	Energy consumption according to VDI cycle		kWh/h		0,79	0,94
		Energy consumption acc. to EN16796:2016		kWh/h		0,6	0,71
	6.7	Turnover output		t/h		52,8	61,9
	6.8	Energy consumption at turnover output		kWh/h		1,07	1,39
Others	8.1	Type of drive control				Variable AC	Variable AC

¹⁾ Measured according to company standard

²⁾ S3 6%

*) Further alternatives are available and will produce other values.

Data is based on standard configurations: Medium battery compartment, h₂₃ = 3300 mm (SWE120) and 3255 mm (SWE140) Duplex Tele Panoramic View mast.

All data are based on table configuration. Other configurations may give other values.

Truck performance and dimensions are nominal and subject to tolerances.

Toyota Material Handling Manufacturing Sweden AB products and specifications are subject to change without notice.

Battery dependent dimensions

BT staxio

Dimensions		Battery change		SWE120			SWE140		
				Lift out		Sideways	Lift out		Sideways
		Battery compartment		Medium	Large	Large	Medium	Large	Large
1.9	Wheelbase	y	mm	1252	1302	1302	1252	1302	1302
4.19	Overall length	l ₁	mm	1906	1956	1956	1906	1956	1956
	without platform			1991/2381	2041/2431	2041/2431	1991/2381	2041/2431	2041/2431
4.20	Length to face of forks	l ₂	mm	756	806	806	756	806	806
	without platform			841/1231	891/1281	891/1281	841/1231	891/1281	891/1281
4.34.1	Aisle width for pallets 1000x1200 crossways	A _{st}	mm	2300	2350	2350	2300	2350	2350
	without platform			2385/2785	2435/2835	2435/2835	2385/2785	2435/2835	2435/2835
4.34.2	Aisle width for pallets 800x1200 lengthways	A _{st}	mm	2287	2337	2337	2287	2337	2337
	without platform			2372/2772	2422/2822	2422/2822	2372/2772	2422/2822	2422/2822
4.35	Turning radius, forks raised	W _a	mm	1403	1453	1453	1403	1453	1453
	without platform			1488/1888	1538/1938	1538/1938	1488/1888	1538/1938	1538/1938
6.4	Battery voltage, nominal capacity, Lead-Acid	K _s	V/Ah	24/225	24/300	24/260	24/225	24/300	24/260
	Battery voltage, nominal capacity, Li-Ion			24/105	24/210	-	24/105	24/210	-
6.5	Battery weight, nominal		kg	192	248	221	192	248	221
	Battery weight, min.—max.			185 - 285	185 - 285	185 - 285	185 - 285	185 - 285	185 - 285

Mast dimensions

SWE120			Simplex	Duplex Tele				Dupl. Tele Panoram. View				Duplex Hi-Lo				Triplex Hi-Lo			
h ₂₃	Lift height (h ₁₃ +h ₃)	mm	1400 1700	2700 2900 3300 3700 4150	2700 2900 3300 3700 4150	2700 2900 3300 3700 4150	2700 2900 3300 3700 4150	2700 2900 3300 3700 4150	2700 2900 3300 3700 4150	2700 2900 3300 3700 4150	2700 2900 3300 3700 4150	2700 2900 3300 3700 4150	2700 2900 3300 3700 4150	2700 2900 3300 3700 4150	2700 2900 3300 3700 4150	3300 3700 4150 4500			
h ₃	Lift	mm	1310 1610	2610 2810 3210 3610 4060	2610 2810 3210 3610 4060	2610 2810 3210 3610 4060	2610 2810 3210 3610 4060	2610 2810 3210 3610 4060	2610 2810 3210 3610 4060	2610 2810 3210 3610 4060	2610 2810 3210 3610 4060	2610 2810 3210 3610 4060	2610 2810 3210 3610 4060	2610 2810 3210 3610 4060	2610 2810 3210 3610 4060	3210 3610 4060 4410			
h ₁	Height, mast lowered	mm	1825 2125	1843 1943 2143 2343 2568	1843 1943 2143 2343 2568	1843 1943 2143 2343 2568	1843 1943 2143 2343 2568	1843 1943 2143 2343 2568	1843 1943 2143 2343 2568	1843 1943 2143 2343 2568	1843 1943 2143 2343 2568	1843 1943 2143 2343 2568	1843 1943 2143 2343 2568	1843 1943 2143 2343 2568	1843 1943 2143 2343 2568	1720 1854 2004 2120			
h ₂	Free lift, ground to top of forks	mm	1400 1700	76 76 76 76 76	76 76 76 76 76	76 76 76 76 76	76 76 76 76 76	76 76 76 76 76	76 76 76 76 76	76 76 76 76 76	76 76 76 76 76	76 76 76 76 76	76 76 76 76 76	76 76 76 76 76	76 76 76 76 76	1180 1314 1464 1580			
h ₄	Height, mast extended	mm	1825 2125	3125 3325 3725 4125 4575	3125 3325 3725 4125 4575	3125 3325 3725 4125 4575	3125 3325 3725 4125 4575	3125 3325 3725 4125 4575	3125 3325 3725 4125 4575	3125 3325 3725 4125 4575	3125 3325 3725 4125 4575	3125 3325 3725 4125 4575	3125 3325 3725 4125 4575	3125 3325 3725 4125 4575	3125 3325 3725 4125 4575	3747 4149 4599 4947			

SWE140			Duplex Tele Panoramic View					Duplex Hi-Lo					Triplex Hi-Lo				
h ₂₃	Lift height (h ₁₃ +h ₃)	mm	2655 2855 3255 3655 4105	2655 2855 3255 3655 4105	2655 2855 3255 3655 4105	2655 2855 3255 3655 4105	2655 2855 3255 3655 4105	2655 2855 3255 3655 4105	2655 2855 3255 3655 4105	2655 2855 3255 3655 4105	2655 2855 3255 3655 4105	2655 2855 3255 3655 4105	2655 2855 3255 3655 4105	2655 2855 3255 3655 4105	2655 2855 3255 3655 4105	2655 2855 3255 3655 4105	3255 3655 4105 4455 4755
h ₃	Lift	mm	2565 2765 3165 3565 4015	2565 2765 3165 3565 4015	2565 2765 3165 3565 4015	2565 2765 3165 3565 4015	2565 2765 3165 3565 4015	2565 2765 3165 3565 4015	2565 2765 3165 3565 4015	2565 2765 3165 3565 4015	2565 2765 3165 3565 4015	2565 2765 3165 3565 4015	2565 2765 3165 3565 4015	2565 2765 3165 3565 4015	2565 2765 3165 3565 4015	2565 2765 3165 3565 4015	3165 3565 4015 4365 4665
h ₁	Height, mast lowered	mm	1868 1968 2168 2368 2593	1868 1968 2168 2368 2593	1868 1968 2168 2368 2593	1868 1968 2168 2368 2593	1868 1968 2168 2368 2593	1868 1968 2168 2368 2593	1868 1968 2168 2368 2593	1868 1968 2168 2368 2593	1868 1968 2168 2368 2593	1868 1968 2168 2368 2593	1868 1968 2168 2368 2593	1868 1968 2168 2368 2593	1868 1968 2168 2368 2593	1868 1968 2168 2368 2593	1720 1854 2004 2120 2220
h ₂	Free lift, ground to top of forks	mm	76 76 76 76 76	76 76 76 76 76	76 76 76 76 76	76 76 76 76 76	76 76 76 76 76	76 76 76 76 76	76 76 76 76 76	76 76 76 76 76	76 76 76 76 76	76 76 76 76 76	76 76 76 76 76	76 76 76 76 76	76 76 76 76 76	76 76 76 76 76	1134 1268 1418 1534 1634
h ₄	Height, mast extended	mm	3125 3325 3725 4125 4575	3125 3325 3725 4125 4575	3125 3325 3725 4125 4575	3125 3325 3725 4125 4575	3125 3325 3725 4125 4575	3125 3325 3725 4125 4575	3125 3325 3725 4125 4575	3125 3325 3725 4125 4575	3125 3325 3725 4125 4575	3125 3325 3725 4125 4575	3125 3325 3725 4125 4575	3125 3325 3725 4125 4575	3125 3325 3725 4125 4575	3125 3325 3725 4125 4575	3747 4149 4599 4947 5247

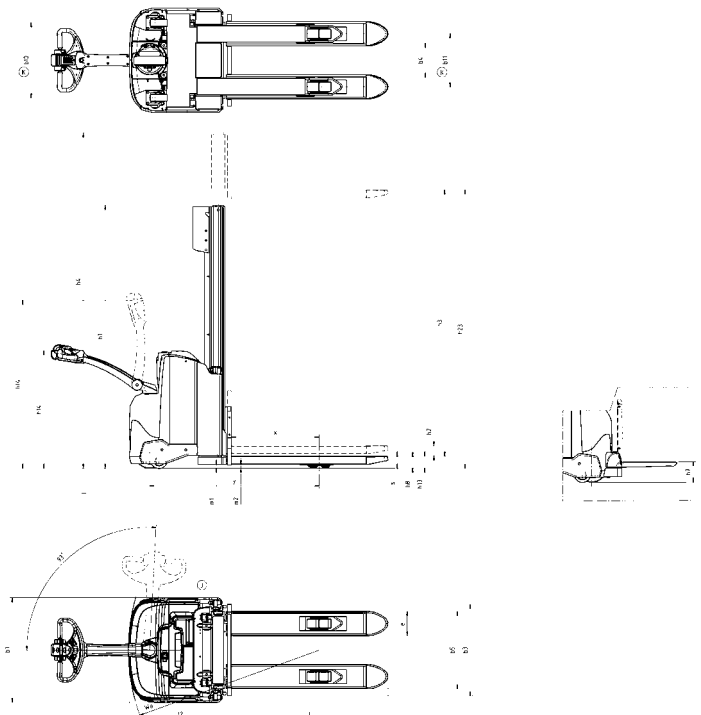

Truck features:

- BT Powerdrive System
- Fingertip controls
- Electronic braking system
- Electronic speed control
- Operator safety
- Storage compartments
- Automatic switch-off
- Click-2-creep
- Programmable performance
- Easy access for maintenance
- Built in charger (option)
- Sensilift (option)
- Flip-up operator platform (option)
- Toyota I_site: truck fleet management system (option)
- Hydraulic oil for low temperatures (option)

